

深圳市晶鴻輝電子有限公司

SHENZHEN JINGHONGHUI ELECTRONICS CO.,LTD.

深圳市福田区福虹路世贸广场群楼4楼

[Http://www.jhdz.com](http://www.jhdz.com)

電話：(755)8365 1619

當前版本 Ver：V1.0

傳真：(755)8387 6331

QQ：40395117

產品規格書 SPECIFICATION

標題 Title：陶瓷諧振器規格書 SPECIFICATION FOR CERAMIC RESONATOR



陶瓷諧振器規格書

SPECIFICATION FOR CERAMIC RESONATOR

ITEM: 陶瓷諧振器

PART NO: ZTA4.0MG

VER: V1.0

Customer (客戶): _____

PART No. (料號): _____

Specification (規格): CERAMIC 4.00MHZ 2PIN

Quantity (數量): 20 pcs

Date (日期): 2011-02-25

Page (頁數): 共八頁 8 pages

| | | | | | |
|------------------|-----|-------------------|-------|--------------------|-----|
| 設計： Issued by | 劉木海 | 審核： Checked by | Allen | 批准： Approved by | 賴茂餘 |
|------------------|-----|-------------------|-------|--------------------|-----|

陶瓷諧振器規格書

SPECIFICATION FOR CERAMIC RESONATOR

編號 Spec No. : **JHH110225- CERZTA4.0MG2P**

頁數 Page : 1 of 8

承認書

Approval Specification Sheet

ACCEPTED/CONFIRMED BY (承認):

| | | | |
|---------------------------------|-----------|------------|----------|
| 承認日期 Date of Approval | 年 Year | 月 Month | 日 Day |
| 承認欄 Approval By | | | |

Approve By (承認單位): _____

Company Stamp (蓋章): _____

Signature (簽名): _____

陶瓷諧振器規格書

SPECIFICATION FOR CERAMIC RESONATOR

編號 Spec No. : **JHH110225- CERZTA4.0MG2P**

頁數 Page : 2 of 8

1 適用範圍

本產品規格書適用於 ZTA4.0MG 型陶瓷諧振器。

2 產品編號

| 產品型號 | 貴公司部品號 | 規格書編號 |
|----------|--------|-------|
| ZTA4.0MG | | |

3 外觀及外形

外觀

標誌清晰、外觀光潔、無汙點和損傷、無變形。

結構

單片樹脂包封型。

除晶片（振子、基板、電容片）外不使用含鉛材料。

外形尺寸

Unit(單位) : mm

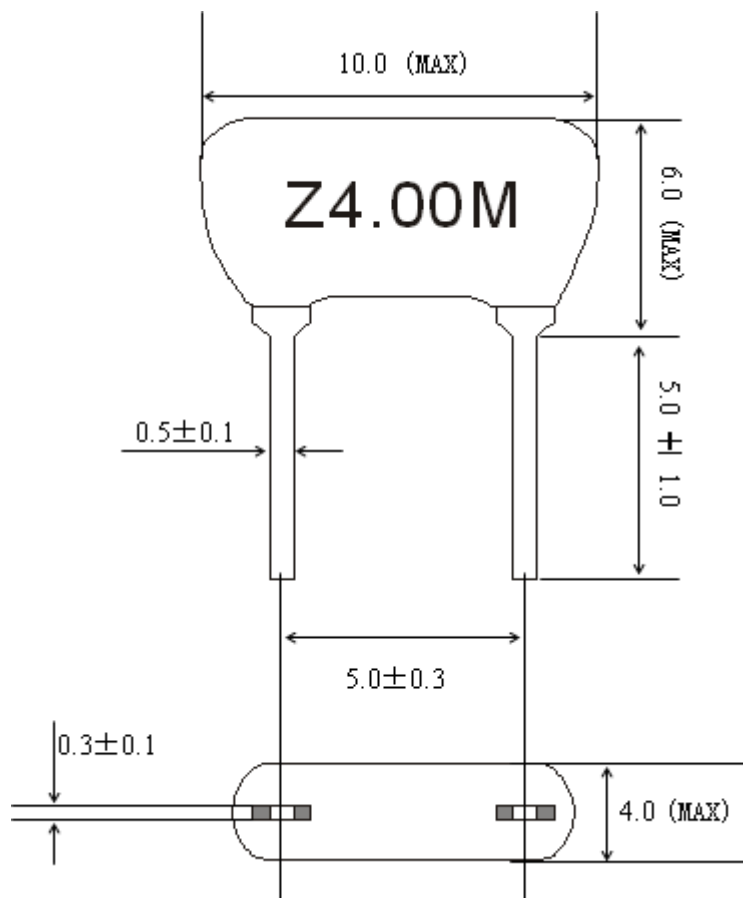

Materials(材料)

| | |
|--------------|-----------------------|
| Terminal(引腳) | Sn plated on Cu (銅鍍錫) |
| Coating(塗料) | Epoxy Resin (環氧樹脂) |

陶瓷諧振器規格書

SPECIFICATION FOR CERAMIC RESONATOR

編號 Spec No. : **JHH110225- CERZTA4.0MG2P**

頁數 Page : 3 of 8

4 電氣性能 ELECTRICAL CHARACTERISTICS

| | Item (項目) | Requirements (要求) |
|---|---|------------------------------|
| 1 | Oscillation Frequency(Fosc) (振盪頻率) | 4.00 MHZ |
| 2 | Frequency Tolerance (頻率公差) | Fosc±0.5 % (MAX) |
| 3 | Resonator Impedance (諧振阻抗) | 30 Ω (MAX) |
| 4 | Operating Temp. Range (工作溫度範圍) | -25°C~+85°C |
| 5 | Temperature Stability (溫度穩定性) | ±0.3% (MAX) (-25°C~+85°C) |
| 6 | Insulation Resistance (絕緣阻抗) | 100MΩ min (D.C. 100V) |
| 7 | Aging(10 years) (10 年老化率) | ±0.3 % |
| 8 | Storage Temp. Range (貯存溫度範圍) | -40°C~+85°C |
| 9 | Test Temp.&Humi.Condition (測試溫、濕度條件) | +10°C~+30°C、40%~80% |

5 測試方法

測試條件

測試應在溫度為+20°C±15°C、相對濕度為 65%±20%RH 的環境下進行，必要時，應在溫度為 (25±3) °C、相對濕度為 (65±5) %RH 的環境下進行。

測試電路

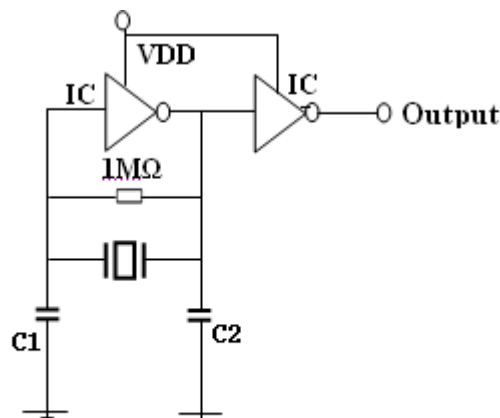

IC: 1/6CD4069UBE×2 VDD= +5V(DC) C1=C2=30pF

陶瓷諧振器規格書

SPECIFICATION FOR CERAMIC RESONATOR

編號 Spec No. : **JHH110225- CERZTA4.0MG2P**

頁數 Page : 4 of 8

6 耐候性能和機械強度 PHYSICAL AND ENVIRONMENTAL CHARACTERISTICS

| | Test Item (試驗項目) | Condition of Test (試驗條件) | Requirements (要求) |
|---|---|--|---|
| 1 | Lead Strength (引腳強度) Lead Pulling (引腳拉力) Lead Bending (引腳彎曲) | Force of 0.5kg is applied to each lead in axial direction for 10sec.. (沿每個引腳軸向施加 0.5kg 力保持 10 秒鐘) When force of 0.25kg is applied to each lead in axial direction.the lead shall folded up to 90° from the axial direction and folded back to the axial direction. (沿引腳軸向施加 0.25kg 力的時候把引腳折彎 90 度後再折回原形) | No mechanical damage and the measured values shall meet Table 1.(無機械損傷，測量值滿足表 1 要求) |
| 2 | Solderability (可焊性) | Lead terminals are immersed in resin for 5 seconds and then immersing in a soldering bath(235±5°C)for 5±0.5sec.(引腳在助劑內浸 5 秒後再浸入 235±5°C 的錫爐內 5±0.5 秒) | The solder shall coat at least 90% of the surface of terminal(引腳上錫覆蓋率≥90%) |
| 3 | Storage in High Temp. (高溫貯存) | After being placed in a chamber with 85°C for 100 hours and then being placed in natural condition for 1 hours, then measure.(85°C 環境下存放 100 小時後取出自然存放 1 小時測試) | The measured value shall meet Table 1(測量值滿足表 1 要求) |
| 4 | Storage in Low Temp. (低溫貯存) | After being placed in a chamber with -25°C for 100 hours and then being placed in natural condition for 1 hours, then measure.(-25°C 環境下存放 100 小時後取出自然存放 1 小時測試) | |
| 5 | Humidity (潮濕) | After being placed in a chamber (Humi.:90~95%RH,Temp.:40±2°C) for 100 hours and then being placed in natural condition for 1 hours, then measure. (溫度 40±2°C ; 濕度 90~95%的環境下存放 100 小時後取出自然存放 1 小時測試) | |
| 6 | Thermal Shock (熱衝擊) | After temperature cycling of -55 °C (30 minutes)to +85 °C (30 minutes)was performed 5 times,Resonator shall be measured after being placed in natural condition for 1 hour(-55°C 下 30 分鐘到+85 °C 下 30 分鐘迴圈 5 次後自然存放 1 小時測量) | |
| 7 | Resistance to soldering Heat (耐焊接熱) | Lead terminals are immersed up to 2.0 mm from the root of terminals in solder bath of 265±5 °C for 10±1seconds, Resonator shall be measured after being placed in natural condition for 1 hour.(引腳距根部 2mm 以下浸入 265±5°C 的錫爐中 10±1 秒取出自然存放 1 小時測量) | |
| 8 | Random Drop (自由跌落) | Resonator shall be measured after 3 times random dropping from the hight of 1 m to concrete floor.(谐振器从 1 米高向水泥地板自由跌落 3 次后測量) | |
| 9 | Vibration (振动) | Resonator shall be measured after being applied vibration as below:(谐振器做如下振动后測量) Vibration Freq.(振动频率): 10 Hz to 55 Hz Amplitude(幅度): 1.5mm Directions(方向): 3 axial directions (三轴向) Time(时间): 1 hour/each direction (1 小时/向) | |

陶瓷諧振器規格書
SPECIFICATION FOR CERAMIC RESONATOR

編號 Spec No. : **JHH110225- CERZTA4.0MG2P**

頁數 Page : 5 of 8

Table 1(表 1)

| Item (項目) | Limit Value (限定值) |
|---------------------------------------|----------------------|
| Oscillation Frequency(Fosc) (振盪頻率) | $\leq \pm 0.3\%$ |
| Resonator Impedance (諧振阻抗) | $\leq \pm 10\Omega$ |

※ Note: The limits in the above table are referenced to the initial measurements.
(上表中的限定值參照初始測量值)

7. NOTICE

(注意)

1. Do not use this product with bend. The component may be damaged if excess Mechanical stress is applied to it mounted on the printed circuit board. (本產品不能折彎使用，在電路板安裝時使用過大的機械壓力可能造成產品損壞。)
2. This specification limits the quality of the component as a single Unit Please make sure that the component is evaluated and confirmed the drawing When it is mounted to your product. (本規格書只規定了部件本身的品質，應用於您的產品時請確認圖紙該產品是否適用。)

陶瓷諧振器規格書

SPECIFICATION FOR CERAMIC RESONATOR

編號 Spec No. : **JHH110225- CERZTA4.0MG2P**

頁數 Page : 6 of 8

8. Cutaway view (剖面圖)

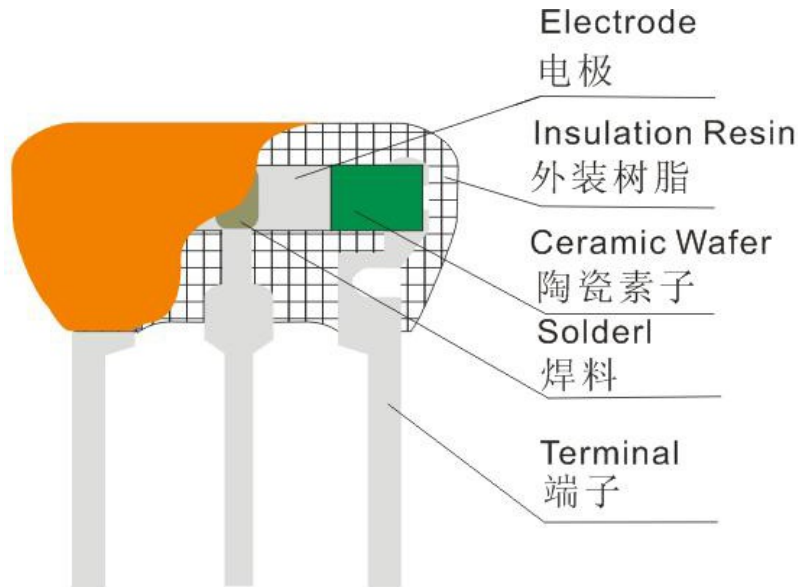

| 構成部件 Component | 材料 Material |
|-----------------------|--------------------------------|
| 陶瓷素子 Ceramic Wafer | PZT 壓電材料 PZT Electric Material |
| 電極 Electrode | 銀 Ag |
| 外裝樹脂 Insulation Resin | 酚醛環氧樹脂 Epoxy Resin |
| 焊料 Solder | 錫/0.7 銅 Sn/0.7Cu |
| 端子 Terminal | 銅 (鍍錫) Cu (Sn plating) |

破壞臭氧層的化學物質使用限制
PROHIBITION TO USE OZONE DEPLETING SUBSTANCES(ODS)
 限制性物質：氟氯化碳、氟氫丁苯、四氯化碳、三氯乙烯（三氯乙烷）
 Prohibited substances:CFCs,Halon,Carbon tetrachloride,Trichloroethane(Methyl chloroform)
 該產品中不含有任何上述物質
 This Product,Assembly,or Component does not contain any of the above mentioned substances.
 該產品的加工工序中不含有任何上述物質。
 This Product,Assembly,or Component in the production process is not use any of the above mentioned substances.

陶瓷諧振器規格書

SPECIFICATION FOR CERAMIC RESONATOR

編號 Spec No. : **JHH110225- CERZTA4.0MG2P**

頁數 Page : 7 of 8

9. PACKAGE (包裝)

To protect the products in storage and transportation, it is necessary to pack them (outer and inner package). On paper pack, the following requirements be requested.

為了在貯存和運輸過程中保護部品，有必要對部品進行包裝（外層和內層包裝）。在包裝紙箱上，應有下列要求：

9-1 Outer Packing Box Dimension (外包裝尺寸)

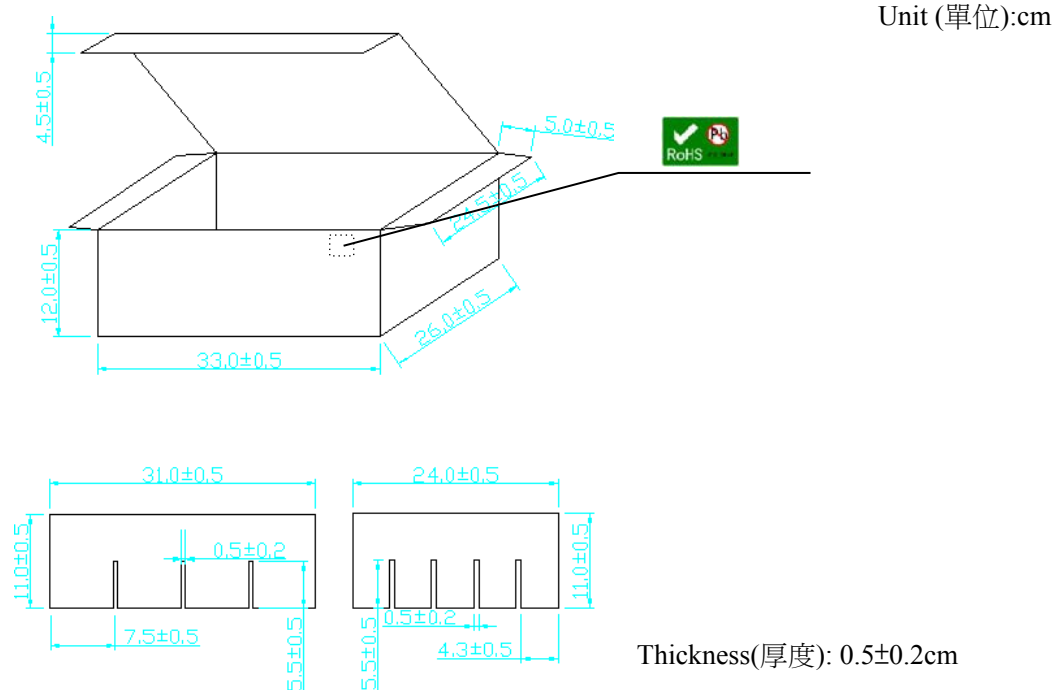

- 1) Mark shall be stuck in the middle of outer box and warning (moistureproof, upward put and placing carefully). Seeing figure.
外包裝箱應有警告標誌（防潮、向上、小心輕放）。
- 2) For Lead-Free soldering products, products protective marking side of outer packing box shall be stuck, Seeing figure.
對無鉛焊接的產品，在外包裝箱的右上方貼上無鉛標示；如圖所示：
- 3) Lead-Free soldering product shall be added (FPB) at the end of Part No.
對無鉛焊接的產品在部品型號末尾處加注(FPB)。

Section of package (包裝材料及包裝方法)

Package is made of corrugated paper with thickness of 0.3±0.1cm. Package has 20 sheets with thickness of 0.5±0.2cm. Each sheet packs 3 plastic bags.

包裝箱用 0.3±0.1cm 厚的瓦楞紙做成，每個包裝箱被厚度為 0.5±0.2cm 的紙板隔成 20 個單格，每個單格內放 3 個塑膠包裝袋。

陶瓷諧振器規格書

SPECIFICATION FOR CERAMIC RESONATOR

編號 Spec No. : **JHH110225- CERZTA4.0MG2P**

頁數 Page : 8 of 8

Quantity of package (包裝數量)

| | |
|---------------------------|--|
| per plastic bag (每袋單位) | 500 pieces of piezoelectric ceramic part 500 只壓電陶瓷部品 |
| per sheet (每格單位) | 3 bags 3 袋部品 |
| per package (每盒單位) | 30,000 pieces of piezoelectric ceramic part 30000 只壓電陶瓷部品 |

Prohibited Substances: (禁用物質)

1. RoHS 規制的六種物質
 - 1) Lead and its compounds 鉛及其化合物
 - 2) Mercury and its inorganic compounds 水銀及其化合物
 - 3) Cadmium and its compounds 鎘及其化合物
 - 4) Hexavalent chromium compounds 六價鎘化合物
 - 5) PBB 多溴聯苯
 - 6) PBDE 多溴二苯醚

2. Prohibition to use Ozone Depleting Substances (ODS)

破壞臭氧層的化學物質使用限制

Prohibition substances

限制性物質：

CFCS,Halon,Carbon tetrachloride,Trichloroethane(Methyl chloroform)

氟氯化碳、氟氫丁苯、四氯化碳、三氯乙烯(三氯乙烷)

We confirm that our products and our production process accord with 'rule of RoHS'.All materials used in this product are registered material undel the law concerning the examination and Regulation of Manufacture of Chemical Substances.

我公司保證我司的產品和生產過程符合“RoHS 規則”，所有產品中使用的材料均是化學物質生產規則中登記的材料。