

# 5x7 SMD OSCILLATOR(HCOMS/TTL)



深圳市晶鸿辉电子有限公司

深圳市福田区福虹路世贸广场裙楼 4 楼

网址: <http://www.jhhdz.com>

电话: (755) 8365 1619 传真: (755) 8387 6331

QQ: 40395117 邮箱: sz\_ysdz@163.com

## 产品规格书 SPECIFICATION

标题 Title: 石英晶体振荡器规格书

### FEATURE

- CMOS compatible logic levels.
- Pin-compatible with standard 7.0×5.0mm packages.
- High precision characteristic covering up to high frequency range.
- Low jitter and tight stability with fundamental or overtone Design.
- Low power standby mode.
- Output Tri-state function.
- Embossed tapping specification.
- Reflow soldering.
- Pb-free and RoHS/Green compliant.

### APPLICATIONS

- Ideally suited designed for discdrives, NB, Networking, GPS/Navigation, Bluetooth, Ethernet, ADSL, VDSL, Fiber channel hand-held electronic products.

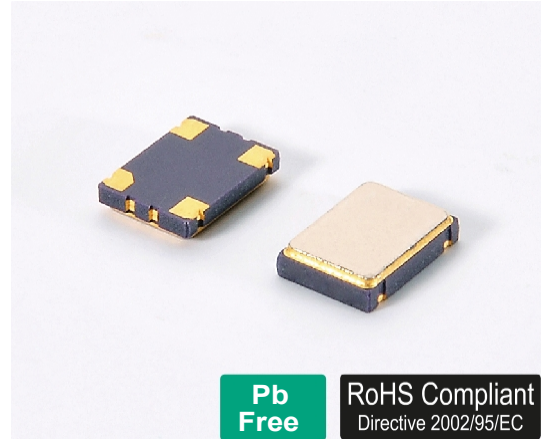

Pb Free

RoHS Compliant  
Directive 2002/95/EC

### Electrical Specifications 电气参数

型号	Holder Type	5x7mm SMD OSCILLATOR
频率范围	Frequency Range	32.768KHz, 1.000 Mhz to 150.000 MHz
总频差	Frequency Stability	±20ppm to ±50ppm
输入电压	Supply Voltage	5.0V or 3.3V ±10% ※(See Notes)
工作温度范围	Operating Temperature Range	-20°C - +70°C / -40°C - +85°C
储存温度范围	Storage Temperature Range	-40°C - +85°C/-55°C - +125°C
占空比	Symmetry (Duty Cycle)	40/60 Standard
输出	Output Load	15pF Hcmos
消耗电流	Current Consumption (15pf only) (5.0V)	1.000Mhz - 35.999Mhz=25mA max
		36.000Mhz - 69.999Mhz=60mA max
		70.000Mhz - 150.000Mhz=80mA max
	Current Consumption (15pf only) ( 1.8V 2.5V 2.85V 3.3V)	1.000Mhz - 35.999Mhz=20mA max
		36.000Mhz - 69.999Mhz=40mA max
		70.000Mhz - 150.000Mhz=60mA max
上升/下降时间	Rise/Fall Time	5 nS max

※Notes:The supply voltage 1.8V, 2.5V, 2.85V also can be made by customer.

### Mechanical Dimensions 外型尺寸

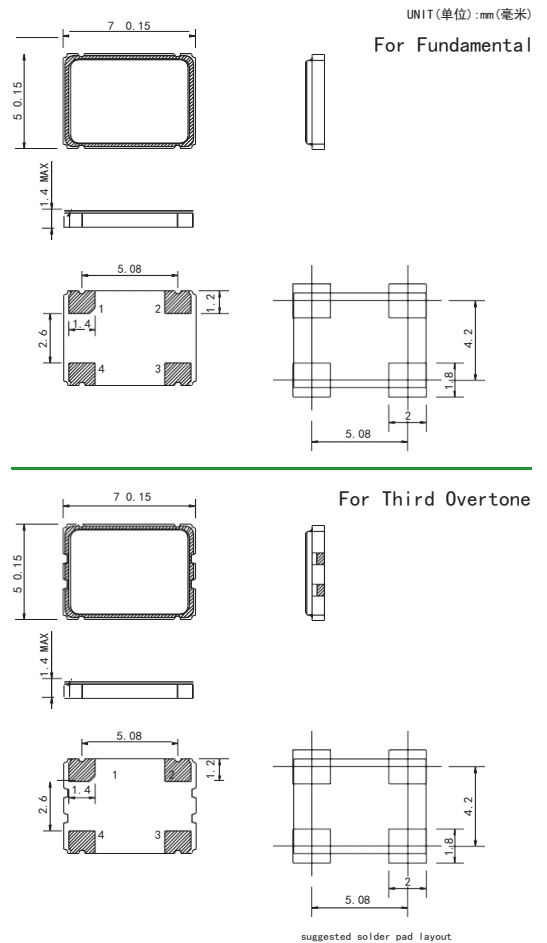

### Test Circuit(测试电路)

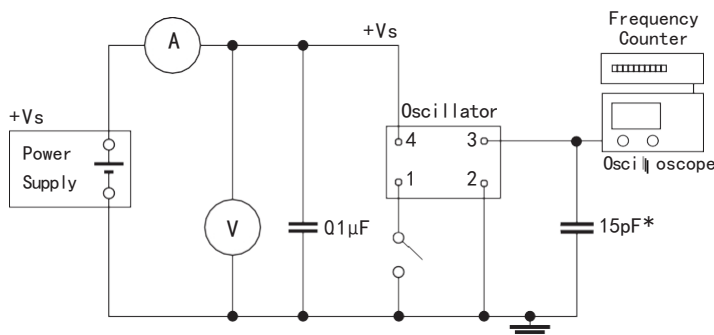

PIN	FUNCTION
1	N/C or Tri-state
2	Ground
3	Output
4	Vdd