

2.5x2.0 32.768KHz Low Power Oscillator



深圳市福田区福虹路世贸广场裙楼 4 楼 网址: <http://www.jhhdz.com>
 电话: (755) 8365 1619 传真: (755)8387 6331 QQ: 40395117 邮箱: sz_ysdz@163.com
产品规格书 SPECIFICATION

FEATURE

- 32.768kHz output SPXO-IC for AT-cut crystal
- Ultra-low current consumption comparable to tuning fork crystal
- Excellent frequency stability over wide temperature range realized by third-order temperature characteristics specific to AT-cut crystal.
- Low power standby mode.
- Reflow soldering.
- Pb-free and RoHS/Green compliant.

APPLICATIONS

- Ideally suited designed for use in Ethernet, network adapter cards, devices, blue tooth, PCMCIA Cards, Palmtop Computer, Portable Applications.

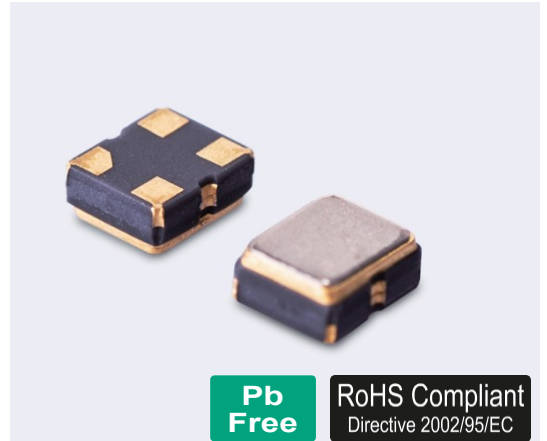

Electrical Characteristics 技术指标

型号	Holder Type	2.5x2.0mm SMD OSCILLATOR
频率输出	Frequency Output	32.768KHz
常温频差	Frequency Tolerance	±10ppm to ±30ppm (at 25°C)
温度频差	Temperature Drift	±15ppm to ±30ppm (at -40°C - +85°C)
输入电压	Supply Voltage	1.8V to 3.3V
工作温度范围	Operating Temperature Range	-20°C - +70°C / -40°C - +85°C
储存温度范围	Storage Temperature Range	-40°C - +85°C / -55°C - +125°C
占空比	Symmetry (Duty Cycle)	45/55 Standard
输出模式	Output Load	15pF Hcmos
消耗电流	Current Consumption (No load condition, VCC=3.0V)	7.2 uA MAX.
上升/下降时间	Rise/Fall Time	130 nS max.
起振时间	Start Time	10 mSec Max.
老化率	Aging	± 3ppm

Mechanical Dimensions 外型尺寸

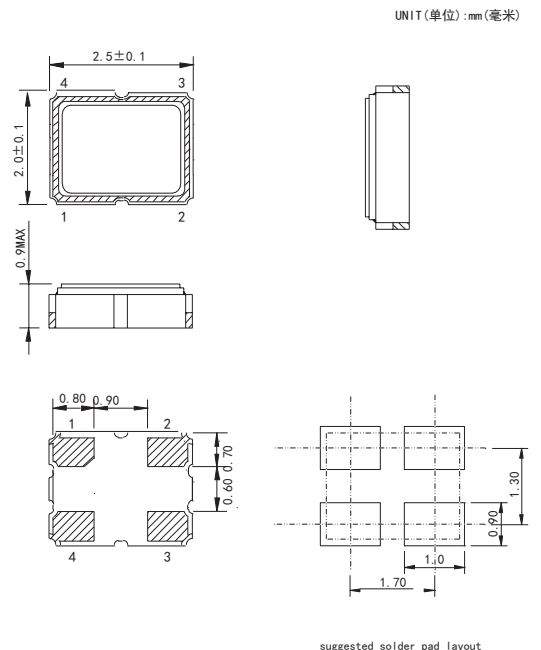

Test Circuit (测试电路)

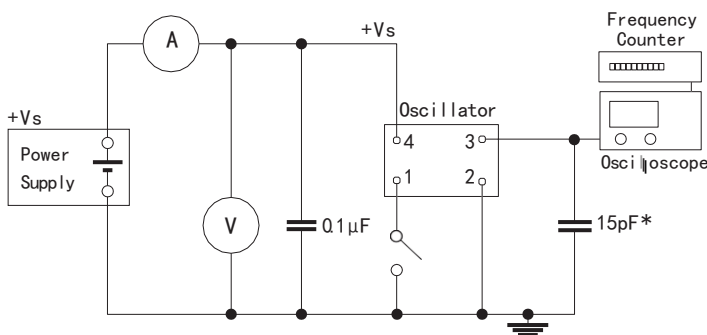

PIN	FUNCTION
1	Tri-state*(See Notes)
2	Ground
3	Output
4	Vdd

*Notes:

Tri-state: PIN 1 connected to Vdd or floating, the product is working properly; connected to GND, stops working.