

3.2x2.5 SMD 32.768KHz Low Power Oscillator



深圳市晶鸿辉电子有限公司

深圳市福田区福虹路世贸广场裙楼 4 楼

网址: <http://www.jhhdz.com>

电话: (755) 8365 1619 传真: (755)8387 6331 QQ: 40395117 邮箱: sz_ysdz@163.com

产品规格书 SPECIFICATION

FEATURE

- 32.768kHz output SPXO-IC for AT-cut crystal
- Ultra-low current consumption comparable to tuning fork crystal
- Excellent frequency stability over wide temperature range realized by third-order temperature characteristics specific to AT-cut crystal.
- Low power standby mode.
- Reflow soldering.
- Pb-free and RoHS/Green compliant.

APPLICATIONS

- Ideally suited designed for use in Ethernet, network adapter cards, blue tooth, PCMCIA Cards, Palmtop Computer, Portable Applications.

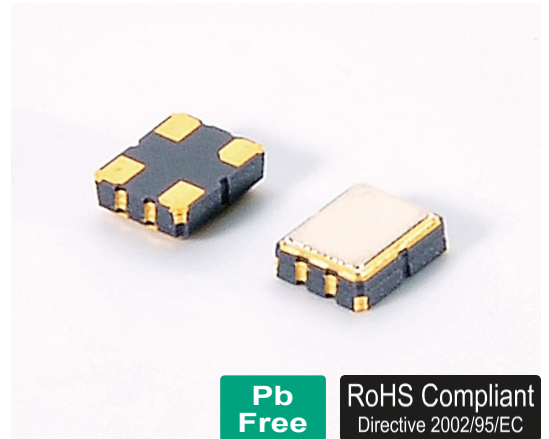

Pb Free

RoHS Compliant
Directive 2002/95/EC

Electrical Characteristics 技术指标

型号	Holder Type	3.2x2.5mm SMD OSCILLATOR
频率输出	Frequency Output	32.768KHz
常温频差	Frequency Tolerance	±10ppm to ±30ppm (at 25°C)
温度频差	Temperature Drift	±15ppm to ±30ppm (at -40°C - +85°C)
输入电压	Supply Voltage	1.8V to 3.3V
工作温度范围	Operating Temperature Range	-20°C - +70°C / -40°C - +85°C
储存温度范围	Storage Temperature Range	-40°C - +85°C / -55°C - +125°C
占空比	Symmetry (Duty Cycle)	45/55 Standard
输出模式	Output Load	15pF Hcmos
消耗电流	Current Consumption (No load condition, VCC=3.0V)	7.2 uA MAX.
上升/下降时间	Rise/Fall Time	130 nS max.
起振时间	Start Time	10 mSec Max.
老化率	Aging	± 3ppm

Mechanical Dimensions 外型尺寸

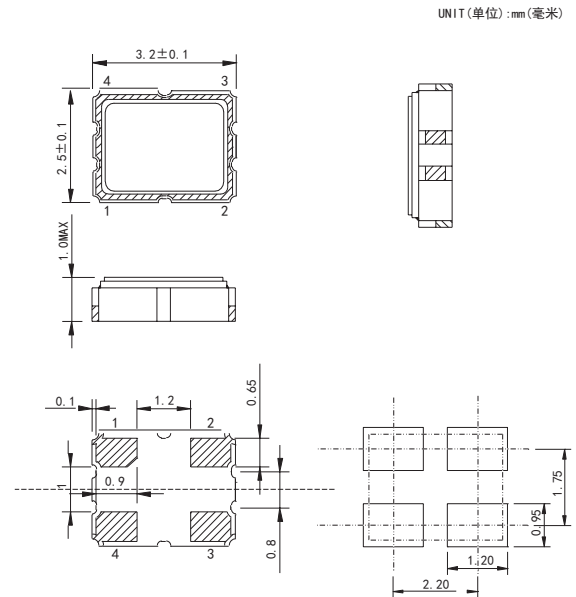

UNIT (单位) : mm (毫米)

Test Circuit (测试电路)

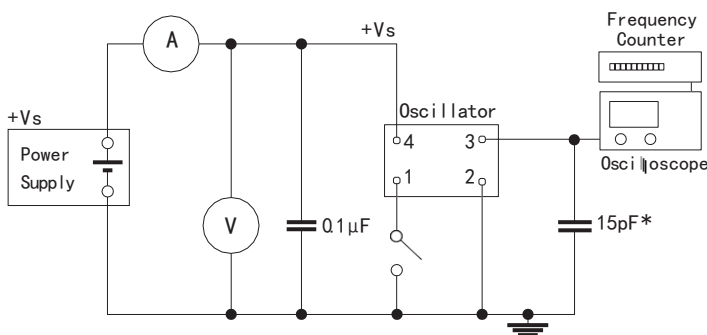

suggested solder pad layout

PIN	FUNCTION
1	Tri-state*(See Notes)
2	Ground
3	Output
4	Vdd

*Notes:

Tri-state: PIN 1 connected to Vdd or floating, the product is working properly; connected to GND, stops working.